

# FR-2H4

## Heavy-Duty Semi-Automatic Fillet Rolling Machine



### Key Points

- Rolling the underhead radius
- 200 – 1000 parts per hour depending on size
- Precise, programmable rolling parameters with 100% in-process checking
- Fast changeover
- Safe, clean working
- Ease of maintenance
- Specially-written user-friendly software in multiple languages
- 3G / Ethernet Modem for remote access
- Industry 4.0 compatible

### Application

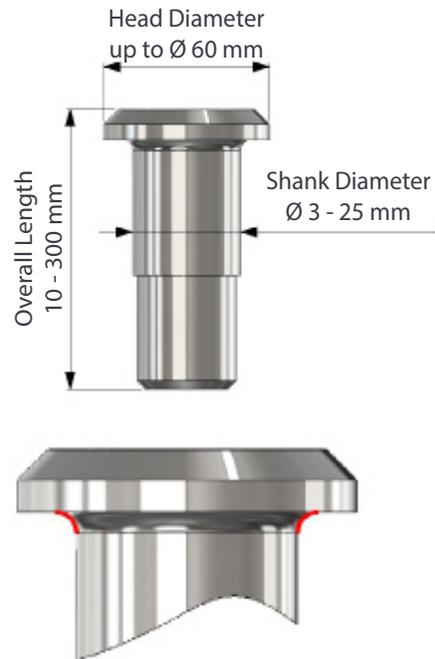

### Features

- Free-standing machine designed to be at a comfortable height for a seated operator
- Manual load and unload
- Automatic cycle initiated by two-hand safety switches
- Safety light curtain to protect the operator during the cycle
- Load cell to measure actual rolling force during each cycle and to check that it is within programmed limits
- Programmable control of rolling force, rpm & time
- Drive unit with inverter controlled spindle motor
- Allen Bradley or Siemens PLC control system with 6" touch-screen (HMI)
- Integrated coolant tank, filter and pump
- Lockable tool tray

 View product at [e-tech.co.uk](https://www.e-tech.co.uk)

 or contact [sales@e-tech.co.uk](mailto:sales@e-tech.co.uk)