

# ADB-X4

Automatic Drill Point and Broach Machine



## Key Points

- Drilling, Pointing, Facing and Broaching of Aerospace Fasteners
- A fast, flexible, reliable machine specially designed for the job
- 800 – 1400 parts per hour depending on size
- Fast changeover
- Safe, clean working and easy maintenance
- >50 E-Tech Drill / Broach machines running on customers' sites
- Specially-written user-friendly software in multiple languages
- Industry 4.0 compatible

## Application

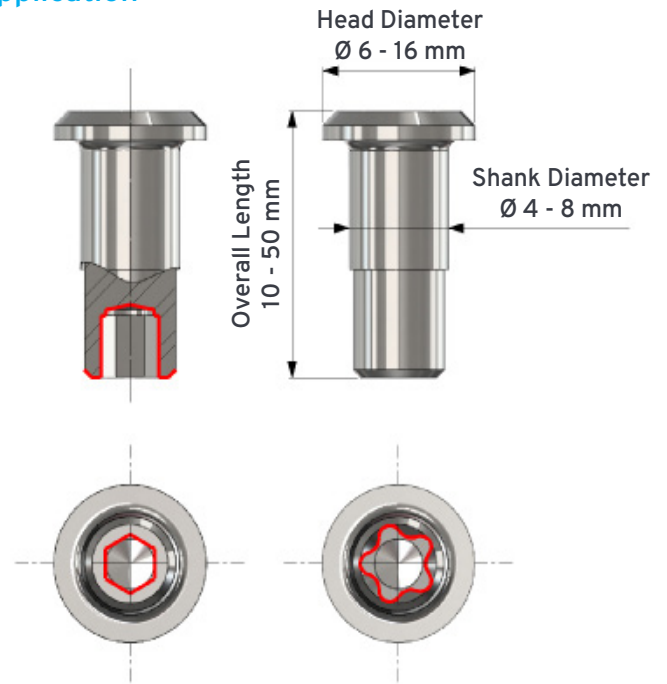

## Features

- 18" dia Vibratory Bowl Feeder
- Indexing Disk with locations to suit 5 different diameters (Indexing Disks can easily be changed)
- 5 stations: Load, Center Drill / Point & Face, Drill, Broach, Unload
- 2 Rotating spindles with independent variable speed up to 6000 rpm
- Hydraulic Feed-rate Control
- Quick-change pre-settable tooling
- Allen Bradley or Siemens PLC control system with 6" touch-screen (HMI)
- Automatic tool breakage detectors

View product at [e-tech.co.uk](http://e-tech.co.uk)

or contact [sales@e-tech.co.uk](mailto:sales@e-tech.co.uk)